

Voice Enhancement Tests per P800/P861/P862



Noise Reduction and Compensation Tests



ALC (Automatic Level Control) Tests



Receive path Voice Improvement Tests (VIT)



Send path EVI (Enhanced Voice Intelligibility) Tests



Zoom-in feature for in-detail analysis of a test results



Graphical and Tabular display of test results



Voice Enhancement Device Test Software

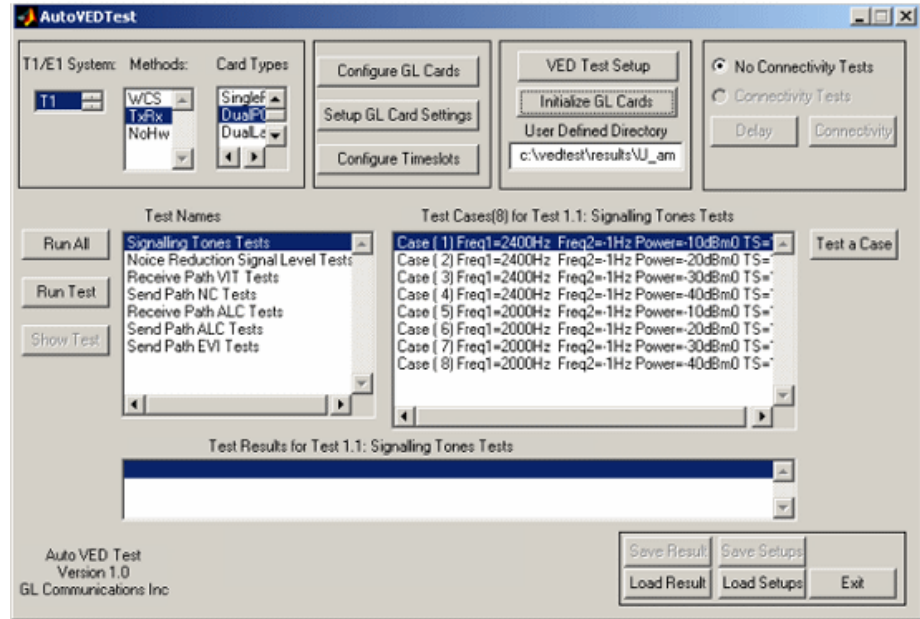

Voice Enhancement Device Per G.160 Test Software

Currently most Digital Echo Cancellers are embedded with VED (voice enhancement device) functionality to further enhance the quality of voice signals. The Voice Enhancement Device Test software is designed to test the functionality of the VEDs (Voice Enhancement Devices) as per ITU-T G.160 standard. Rin and Sin files (stimulus) are prepared by the Auto VED Test software in accordance with user inputs. This software can be used to perform the following tests:

- Voice enhancement tests per P800/P861/P862
- Test 2.1 Noise Reduction (NR) tests
- Receive path ALC (Automatic Level Control) tests
- Send path ALC tests
- Noise Compensation (NC) tests
- Test 1.1 Signaling tones tests
- Receive path Voice Improvement tests (VIT)
- Send path EVI (Enhanced Voice Intelligibility) tests

The software applies the Rin and Sin simultaneously to the VED under test and captures the Sout/Rout (the output of VEDs) signal for analysis. Rout and Sout files are captured and automatically assessed. The software displays objective test results. The detailed graphical analysis of tests is also a click away to gauge overall performance of the VEDs. The performance of the VED is described by VQT (voice quality test) parameters such as PESQ, PAMS, PSQM, etc., which are graphically presented in the test results.

Main Features:

- Available for MS-Windows OS (WIN 98/NT) with user-friendly graphical user interface.
- Compatible with GL's well proven UltraT1/E1 PCI Cards or Laptop T1/E1 Portables.
- Performs Real-time as well as off-line analysis.
- Auto analysis of the response according to G.160 requirement.
- Tabular Pass/Fail Results.
- Detailed graphical results for individual test, overall test.
- Users can zoom-in on any test result to further investigate

For more details, visit http://www.gl.com/SA_VEDTesting.html



GL Communications Inc.

818 West Diamond Avenue - Third Floor Gaithersburg, MD 20878 • (V) 301-670-4784 (F) 301-670-9187
 Web Page Address: <http://www.gl.com/> • E-Mail Address: gl-info@gl.com

VED Test System

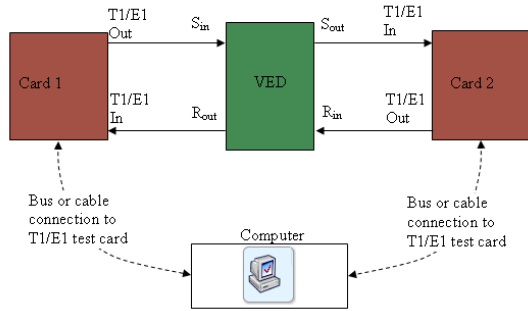

VED Test System

The image to the left provides a graphical representation of the Auto VED test system. The figure displays Two Ultra T1/E1 Cards with digital and analog inputs and outputs. (Alternatively, GL's Dual Laptop T1/E1 Analyzer can be used for convenience and portability.) Digital inputs and outputs are used to interface T1/E1 lines of the VED under test with computers.

Tests to evaluate Voice Enhancement Devices

Following are the basic tests needed to fully evaluate the characteristics of voice enhancement devices:

- Noise Reduction tests (for the receive path)
These tests are designed in way that two VQT (voice quality tests) are performed. The NR performance is evaluated by comparing the VQT 1 score with the VQT 2 score. (Note: VQT1 is the voice quality test between the reference file, and the degraded file. Degraded files are obtained by added noise to the reference file. VQT2 is performed between the Rout (the voice enhancement devices improved signal) and the reference file.
- Noise Compensation tests (for the send path)
These tests are evaluated by the Sout signal power versus the noise power signals.
- Automatic Level Control tests (receive and send paths)
The ALC tests are evaluated by the Sout (or Rout) signal power versus Sin (or Rin) power levels.

Graphical Analysis of Test Results

- Noise Reduction Signal Level, and Signaling Tones Test Results, with Rout Power in dBmo versus Time in seconds.

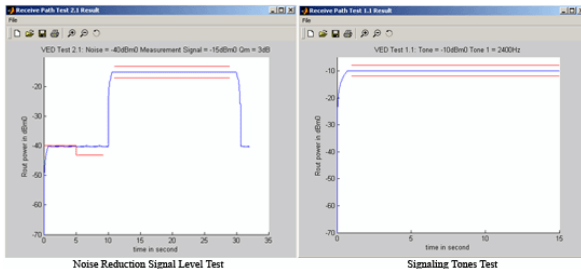

- Receive Path VIT Results, with PESQ LQ Score versus Impairing Signaling Power in dBmo.
- Send Path EVI Tests Results, with PAMS LE Score versus Noise Power in dBmo.

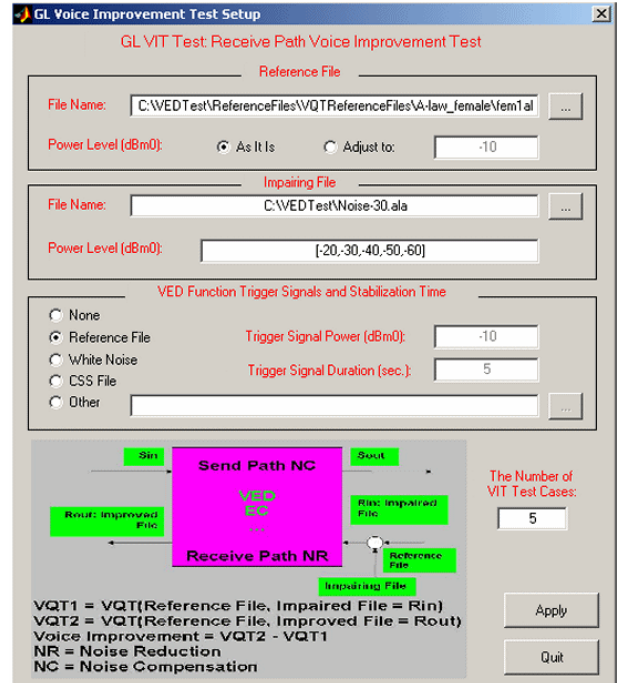
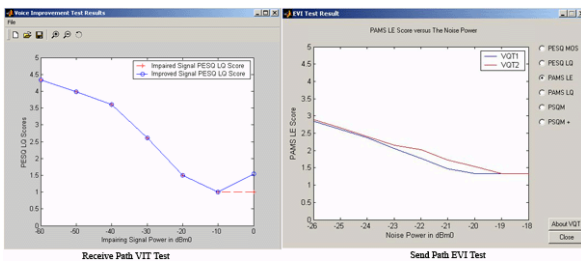

Buyers Guide

- [XX069](#) - Automated Voice Enhancement Device Test Software
- [VQT001](#) - w/VQT-PAMS and PSQM
- [VQT003](#) - w/VQT-PESQ upgrade

Related Software

- [XX063](#) - Echo Path Delay/Loss Measurement Software
- [XX020](#) - Record/Playback File Software
- [XX600](#) - Basic Client/Server Scripted Control Software
- [XX610](#) - w/Transmit and Receive File Capability
- [XX630](#) - w/DSP Capability

Related Hardware

- [HDT001/HDE001](#) - HD T1 / E1 Card w/ Basic Analyzer Software
 - [UTE001](#) - Portable USB based Dual T1 / E1 Laptop Analyzer
- * Specifications and features subject to change without notice.